

## STARTER BATTERIES X SERIES



### Top Performance **ULTRALIFE**

**12 V / 5.0 – 7.5 – 9.2 – 13.8 – 18.4 Ah**

Ultralight starting batteries based on lithium iron phosphate technology. Specifically designed to ensure **maximum life** for high cranking current applications, such as start batteries in motorbikes, cars, jet sky, ATVs, Quads, vintage cars/motorbikes, ULMs and go-karts.

*This family of product is suitable for replacing all the Lead Acid battery type usually installed today without requiring any change to the vehicle electric system. Please check our online configurator to choose the right model for your application.*

#### Exclusive features

- Weight reduction: 50% lighter than traditional batteries
- Ultra rapid complete charge: 100% in less than 30'
- Ultra rapid Partial charge: 50% in less than 10'
- Lowest self discharge rate: < 0,3 % daily
- Longer life cycle: up to **7000 charge/discharge cycles**
- Fit any mounting position
- Very good behaviour at high temperature

#### Eco-compatible and safe

- Lithium Iron Phosphate cells make the accumulator safer
- BMS with microprocessor embedded
- No liquids inside
- Low impact materials
- No lead nor other materials
- Robust ABS recyclable case

#### Quality

- QC on each piece for every step of the assembling process
- Robotized assembly
- Cutting edge last generation components

#### Certifications

- EMC compatibility [ EN 61000-6-1, EN 61000-6-3 ]
- CE declaration
- ROHS compliant [ 2002/95/EC ]
- Test IEC 62133 – Item 4.3.7
- UL1642 Cells certification

#### Wall charger (optional)

- Battery can be charged from grid using wall charger **Aliant™ CB1210 / CB1203** or compatible models

Find the right battery for your vehicle → [www.go-aliant.com](http://www.go-aliant.com)

## Specifications

Model	X2	X3	X4	X6	X8
Nominal Voltage	13,2 V				
Capacity	5 Ah	7,5 Ah	9,2 Ah	13,8 Ah	18,4 Ah
CA Current (10s)	240 A	360 A	480 A	720 A	960 A
CA Current @ 23°C	270 A	400 A	540 A	810 A	1080 A
CCA Current @ -18°C	200 A	300 A	400 A	600 A	800 A
Nominal charge current	6 A @ 25°C	9 A @ 25°C	12 A @ 25°C	18 A @ 25°C	24 A @ 25°C
Max charge current	10 A @ 25°C	15 A @ 25°C	20 A @ 25°C	30 A @ 25°C	40 A @ 25°C
N° cycles	<b>5000 cycles @ 80% D.o.d. (charge 1C / discharge 1C)</b> > 1000 cycles @ 100% D.o.d. (charge 1C / discharge 10C) 2000 cycles @ 80% D.o.d. (charge 1C / discharge 10C) 7000 cycles @ 70% D.o.d. (charge 1C / discharge 1C)				
Shelf life	More than 1 year without any recharge				
Charging voltage	14,4 V				
Max charging voltage	14,6 V				
Weight	≈ 0.88 Kg	≈ 1.25 Kg	≈ 1.62 Kg	≈ 2.50 Kg	≈ 3.24 Kg
Dimensions [mm]	L148 x P67 H85	L148 x P67 H112	L148 x P67 H140	L148 x P134 H140	L148 x P134 H140
Ambient temperature	-30°C / +60°C [ operative and storage ]				
Max altitude	5000 m				
<b>Equivalent Lead Acid battery</b>					
➤ <b>Street Use</b>	<b>Up to 8 Ah</b>	<b>Up to 12 Ah</b>	<b>Up to 18 Ah</b>	<b>Up to 24 Ah</b>	<b>Up to 35 Ah</b>

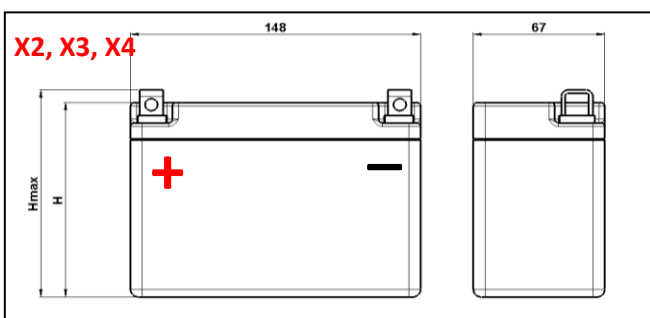

## Dimensions [mm]

Model	H	Hmax
<b>X2</b>	78	85
<b>X3</b>	105	112
<b>X4</b>	133	140

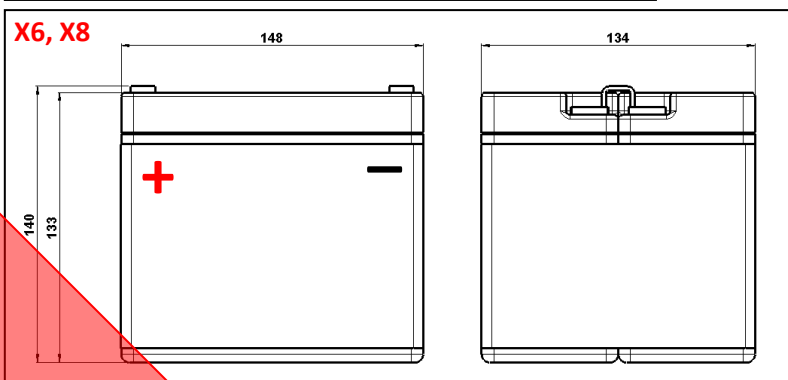

[www.go-aliant.com](http://www.go-aliant.com)

Aliant™ batteries must be charged exclusively with Aliant™ battery chargers; using other manufacturers' chargers will immediately invalidate the product warranty. Do not use battery maintainer with Aliant™ batteries. Do not short. **Read carefully User Manual before using the battery.** This datasheet may be changed by Elsa Solutions without notice. Aliant™ batteries are not homologated for regular road use in cars.